

BOX FIT

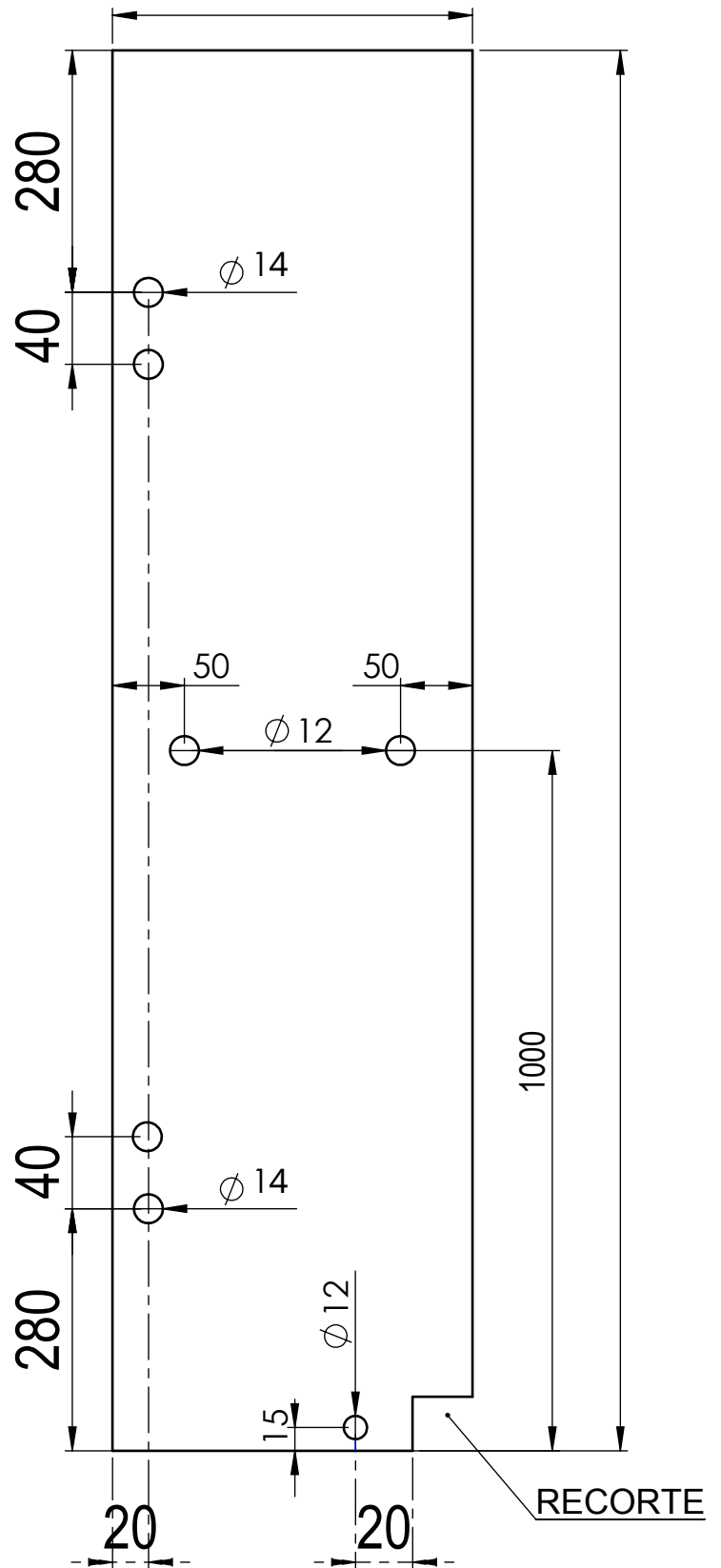
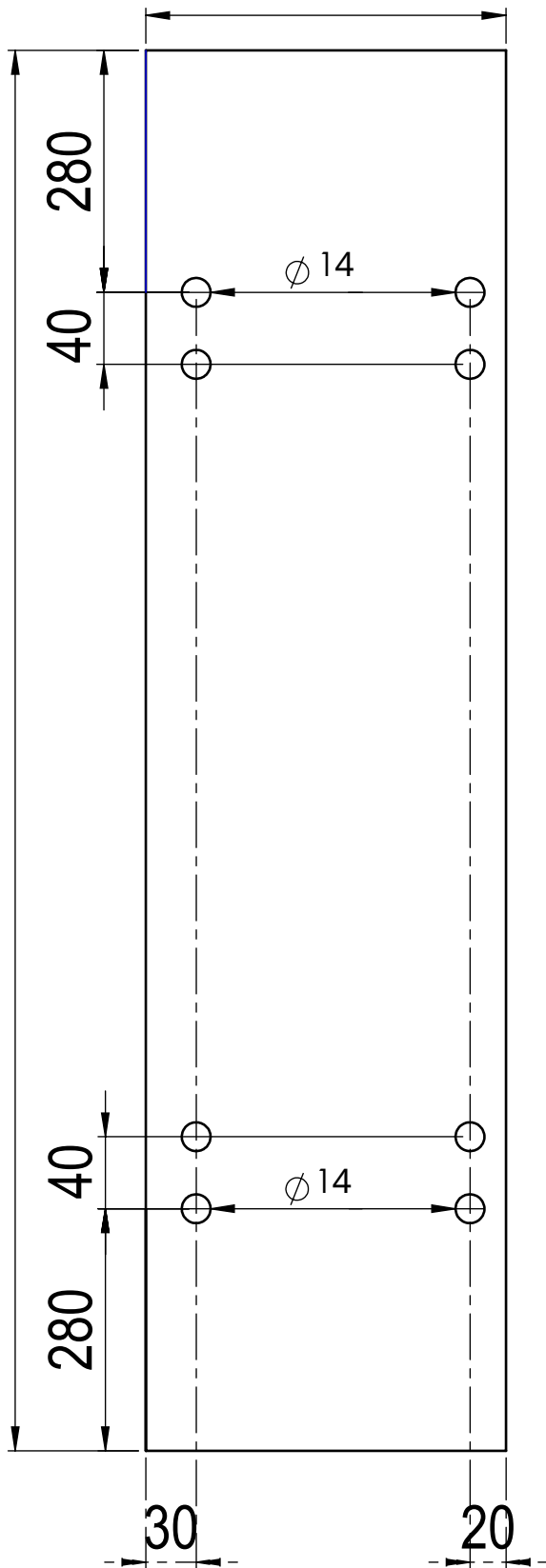

DETERMINAR A LARGURA DE CADA PORTA

((LARGURA DO VÃO) - (20 MM)) E (DIVIDE 2)

EXEMPLO: $(1000-20)=980/2 = 490$ mm

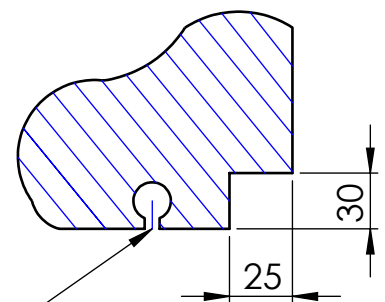

CORTE PARA ALÍVIO DE TENSÃO

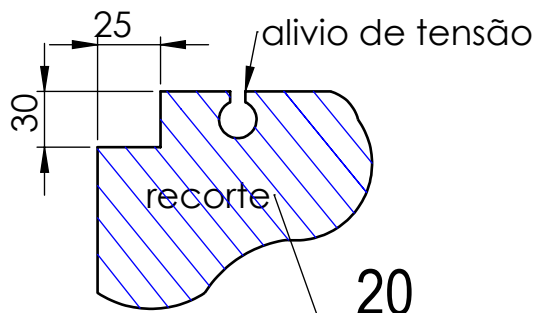

PORTA FIT

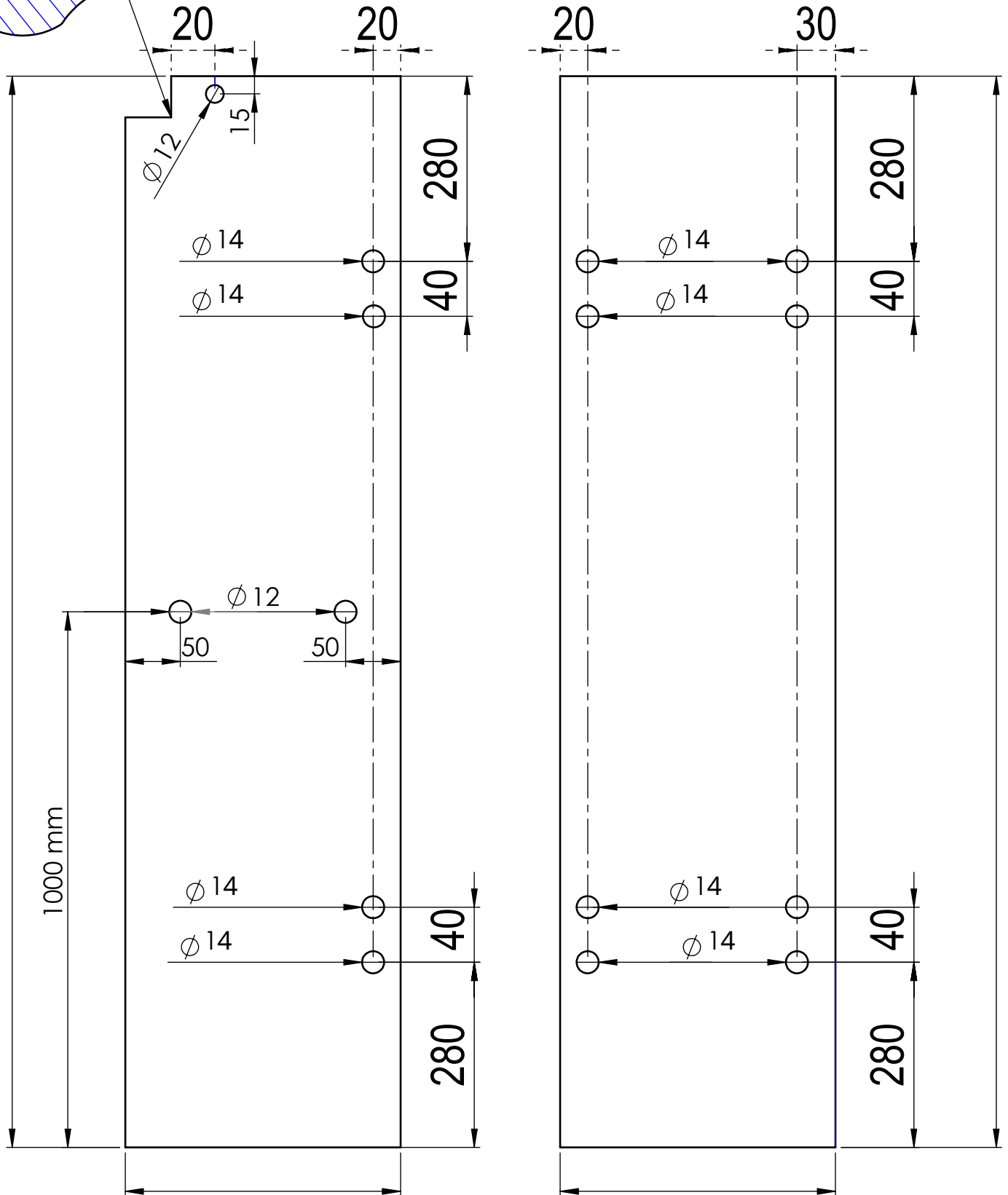

DETERMINAR A LARGURA DE CADA PORTA

((LARGURA DO VÃO) - (20 MM)) E (DIVIDE 2)

EXEMPLO: $(1000-20)=980/2 = 490$ mm